

## NANOCRYSTALLINE MINIATURE CORES

### PART#: 22-17-10

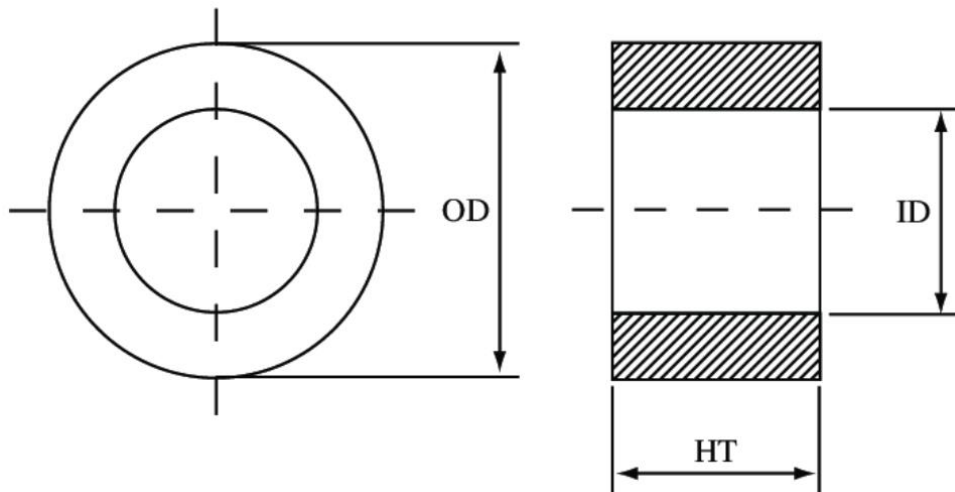

### CORE AND CASE DIMENSIONS

CORE OD MM	CORE ID MM	CORE HT MM	CASE OD MM	CASE ID MM	CASE HT MM
22.00	17.00	10.00	24.60	15.40	12.00

### CORE SPECIFICATIONS

- Outer Diameter D: 22mm (+0.5/-0)mm
- Inner Diameter d: 17mm (-0.5/+0)mm
- Height h: 10mm (+0.2/-0)mm
- Cross-Sectional Area  $A_e$ : 0.20cm<sup>2</sup>
- Mean Magnetic Path Length  $l_e$ : 6.12cm
- Stacking Factor: 80%
- Average Core Weight: 9.0grams
- Operating Temperature: -25°C~+110°C
- Max Temperature:- 130°C
- Input Current (mA):- 25mA
- Guaranteed Minimum Output Voltage (mV): 0.60mV
- Frequency: 50Hz
- $Al_s(\mu H)$  Typical: 25 $\mu H$  (@1KHZ/1.0V)

